



COMPLETE GUIDE TO 3D PRINTING & MANUFACTURING

-  Find out how to choose which process is best for your project.
-  Learn the most cost-effective ways to 3D print using our platform.
-  Discover different finishing levels available for 3D printing processes.



CHOOSING WHICH PROCESS IS BEST FOR YOUR PROJECT

+ There's no one-size-fits-all approach to selecting the best manufacturing process for your parts or products. The right choice depends on three key factors:

- Production quantities
- Part size
- Required material properties

✓ We have a certified partner network for the following technologies:

- Polyjet
- Metal 3D Printing
- CNC Machining
- Injection Moulding



Stereolithography (SLA)

- Aesthetically pleasing, visual parts.
- Models, props & exhibition items.
- Prototypes & master patterns.
- Small series manufacturing.



Selective Laser Sintering (SLS)

- Robust, high temperature parts.
- Functional, clip features, mechanical properties.
- Jigs & fixtures.
- All stages of production.



Multi Jet Fusion (MJF)

- Functional prototypes & end use parts.
- Very similar process and applications as SLS.



Liquid Crystal Display (LCD)

- Excellent visual surface finishes.
- Similar to SLA - resin based.



Fused Deposition Modelling (FDM)

- Early stage prototypes and models.
- Functional & strong parts.
- Small batches.

CHOOSING WHICH PROCESS IS BEST FOR YOUR PROJECT

 There's no one-size-fits-all approach to selecting the best manufacturing process for your parts or products. The right choice depends on three key factors:

- Production quantities
- Part size
- Required material properties

 We have a certified partner network for the following technologies:

- Polyjet
- CNC Machining
- Metal 3D Printing
- Injection Moulding

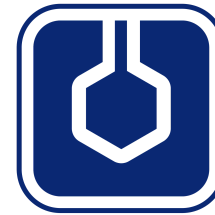

Vacuum Casting

- Small to medium production runs.
- End-use parts, high quality prototypes.
- Surface finish similar to injection moulding.
- Overmoulding capability.



Reaction Injection Moulding

- End-use parts.
- Medium to large production runs.
- Larger parts.

COST-EFFECTIVE WAYS TO 3D PRINT - SLA & LCD

+ The price of SLA/LCD 3D printing is generally down to several factors including:

- Part volume
- Density
- Boundary box
- Material
- Orientation
- Hollow / Non-hollow

We have a minimum order value of £90. Quantities of 50+ will require a review.

A cart that is priced above £5,000 will also require a review so our team can ensure you're getting the best price possible.



Disclaimer: All uploads on our online platform are subject to review.



Stereolithography (SLA)



Liquid Crystal Display (LCD)

These resin-based 3D printing technologies build in layers and require support structures.

- The taller the Z-axis, the longer the lead time will be. The lower the Z-axis means that the build will be quicker and cheaper. This isn't always possible as sometimes definition & detail may be lost, our team can best advise so that the Z-axis is as low as possible to be optimal for price & quality.
- The part needs to take up the smallest area within the platform, as small of a boundary box as possible. This could mean rotating the part slightly so it's footprint on the platform is as small as can be.
- If parts are hollowed out, they will use less material and be cheaper.

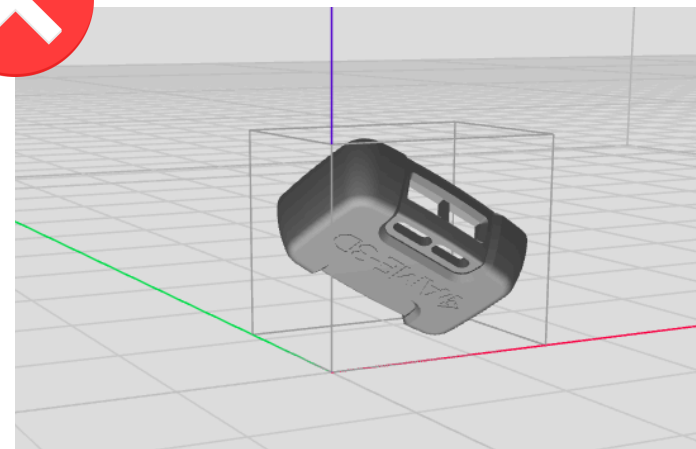

As you can see, the part is orientated so that the bounding box requires more space on the platform. This will be more expensive. This will also require more supports = more material.

Either orientation on the right is correct. However, the top one is the cheapest & quickest as it is building flat. This may not always be optimal for quality though. Our staff will advise when reviewing.

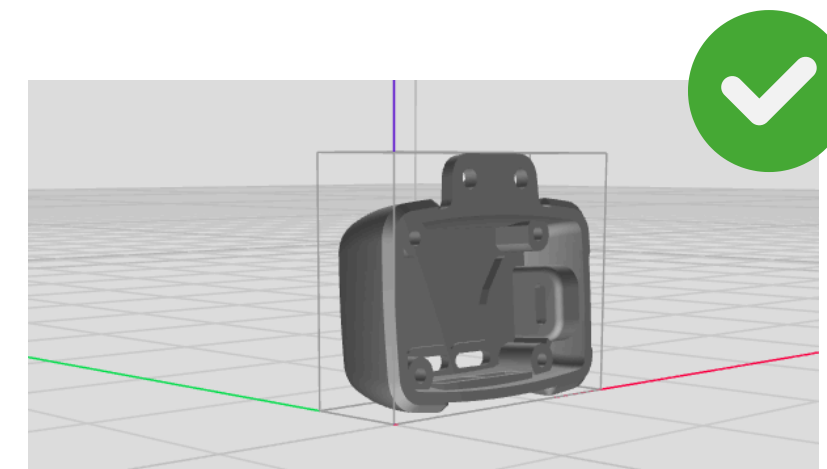
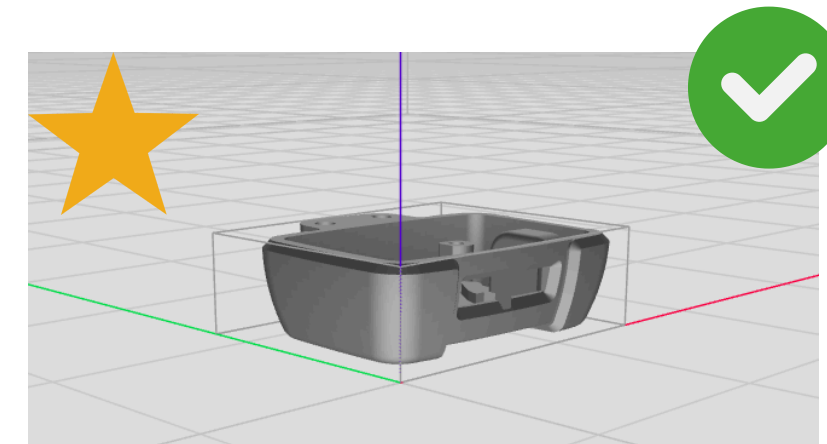

COST-EFFECTIVE WAYS TO 3D PRINT - SLS & MJF

+ The price of SLS/MJF 3D printing is generally down to several factors including:

- Part volume
- Density
- Boundary box
- Material
- Orientation
- Hollow / Non-hollow

We have a minimum order value of £90. Quantities of 50+ will require a review.

A cart that is priced above £5,000 will also require a review so our team can ensure you're getting the best price possible.



Disclaimer: All uploads on our online platform are subject to review.



Selective Laser Sintering (SLS)



Multi Jet Fusion (MJF)

These powder-based 3D printing technologies build in layers and parts don't require supports due to the self-support powder around and layer fusion. No overhang limitations.

- As with SLA, the taller the Z-axis, the longer the lead time will be. The lower the Z-axis means that the build will be quicker and cheaper.
- The part needs to take up the smallest area within the platform, as small of a boundary box as possible. This could mean rotating the part slightly so it's footprint on the platform is as small as can be.
- If parts are hollowed out, they will use less material and be cheaper.

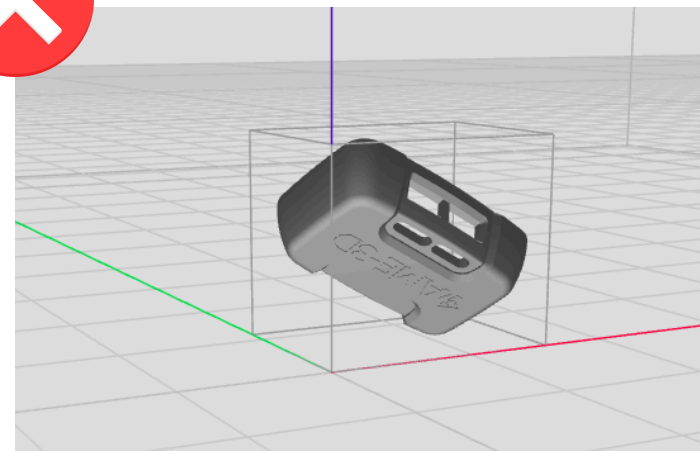

As you can see, the part is orientated so that the bounding box requires more space on the platform. This will be more expensive.

Either orientation on the right is correct. However, the top one is the cheapest & quickest as it is building flat.

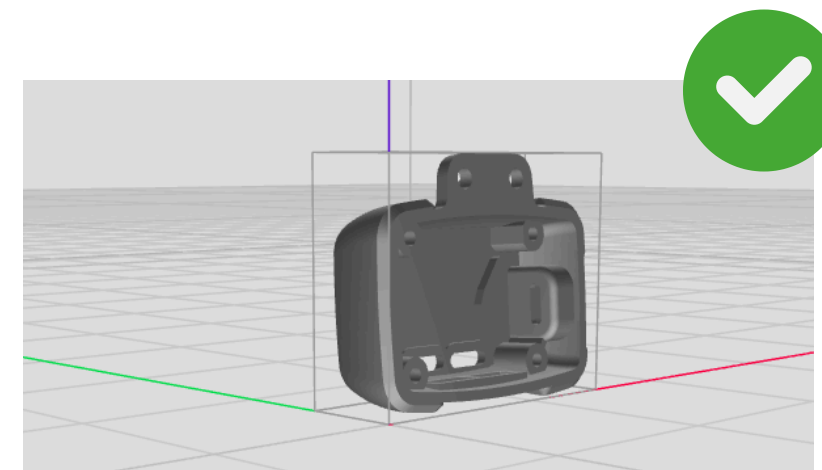
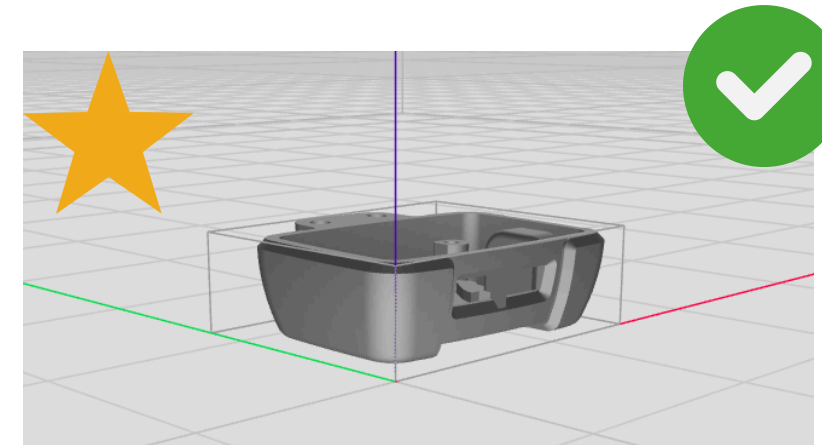

FINISHING OPTIONS AVAILABLE FOR 3D PRINTING

 Different finishing levels and options are available for both SLA, LCD, MJF and SLS.

For vacuum casting, finishes are applied to the SLA master which are replicated in the mould.

 Colours can be matched to RAL codes.



Disclaimers:

- Any additional paint will add microns to parts.
- Specific finishes can impact material properties such as flame retardancy.



Stereolithography (SLA)

- Grade 1 - Support removal & shotblast.
- Grade 2 - G1 + Sanding to remove build lines.
- Grade 3 - G1+2 + Polish, wet sanding, painting in either matt, satin or gloss.



Selective Laser Sintering (SLS)

- Vapour smoothing
- Colour dye
- Shot peen
- Sealing
- Beadblast
- Painting



Multi Jet Fusion (MJF)

- Vapour smoothing
- Colour dye
- Shot peen
- Sealing
- Beadblast
- Painting



Liquid Crystal Display (LCD)

- Grade 1 - Support removal & shotblast.
- Grade 2 - G1 + Sanding to remove build lines.
- Grade 3 - G1+2 + Polish, wet sanding, painting in either matt, satin or gloss.



READY TO START YOUR PROJECT WITH AME?

+ INFO@AME-3D.CO.UK

+ 01909 550 999

+ AME-3D.CO.UK

+ Instant 3D Printing Quote -
AME-3D.CO.UK/ONLINE-3D-PRINTING-QUOTE

